

IF IN DOUBT ASK

INFORM DRAWING OFFICE OF ERRORS

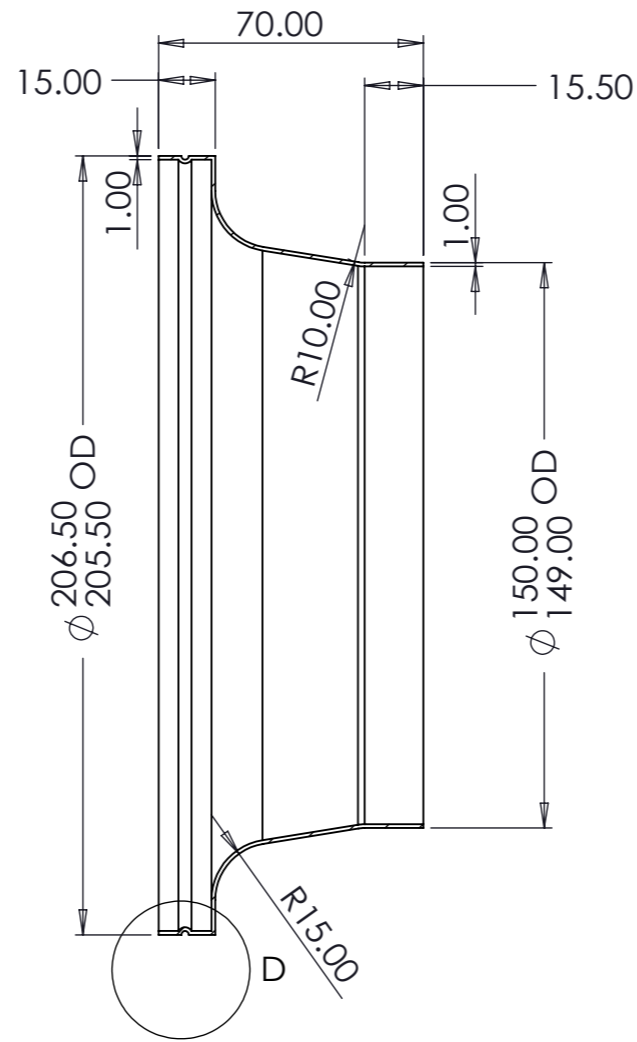

SECTION A-A
SCALE 1 : 2

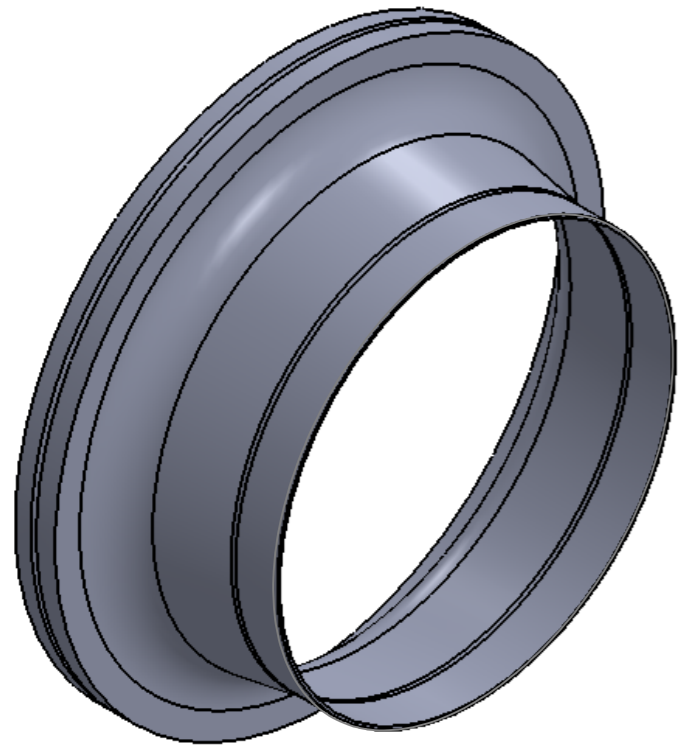
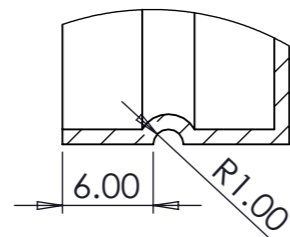
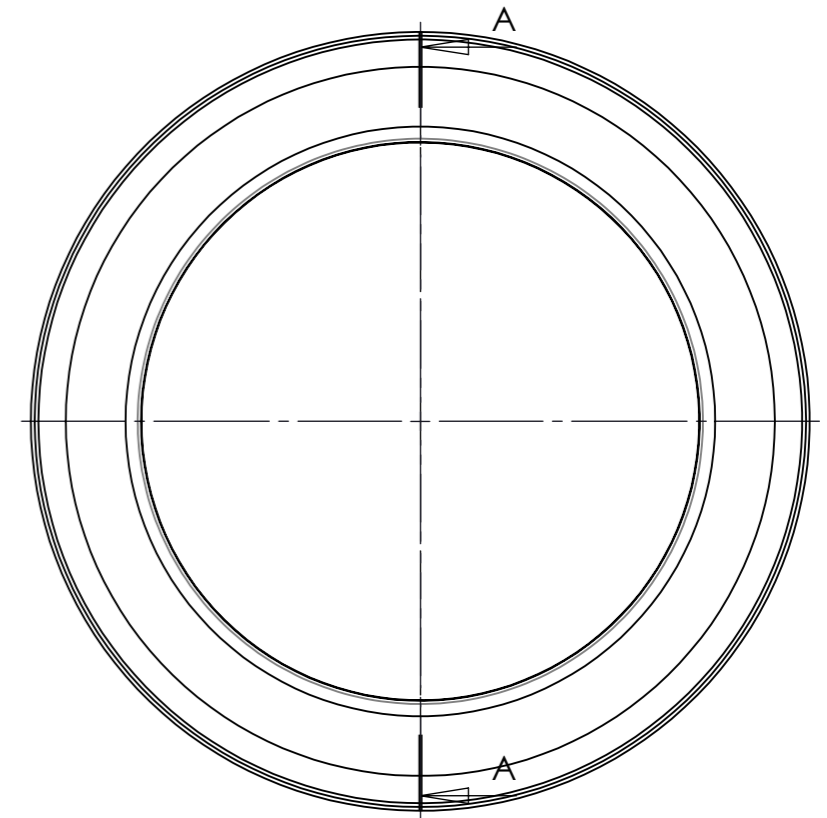

DETAIL D
SCALE 2 : 1

Production: Simon Farren

Costing: Simon Farren

A3 SHEET 1 OF 1

ISSUE	DESCRIPTION	INITIALS	E.C.N. No	DATE	ALL DIMENSIONS IN MILLIMETERS			REMOVE ALL BURRS AND SHARP EDGES UNLESS OTHERWISE STATED	Reverie Limited Unit 2 Chandlers Row Colchester Essex CO1 2HG 01206 866663 www.reverie.ltd.uk	DRAWN	APP	PART NUMBER	
1	ORIGINAL ISSUE	AVT		06/03/2013	TOLERANCES (AT 20C) UNLESS OTHERWISE STATED					HOLES TO BS4500 1985. THREADS TO BS3643 1981 METRIC COURSE. BSP THREADS TO BS 2779 MED FIT	BM		150-206mm
					NOMINAL LINEAR DIMENSIONS			THIS A DRAWING IS A PRIVATE AND CONFIDENTIAL COMMUNICATION	DATE		TITLE		
					OVER-INCL	<0.00	0.00		14/01/2014		Spun High Flow Adapter		
					0-200	+/- 0.50	+/- 0.15	SURFACE FINISHES	FINISH		MATERIAL		
					250-1000	+/- 1.00	+/- 0.20	MILLING N8	SCALE		INSPECTION LEVEL		
					1000 PLUS	+/- 2.00	+/- 0.30	TURNING N7	Do Not Scale Drawing		PART QUALITY GRADE		
								GRINDING N6	MASS		DRG. No.		
								ANG DIMS +/- 0.5°					